

IRBIS EYEPieceLESS THERMAL SIGHT



OPERATION MANUAL

Contents

1. Product Operation.....	3
1.1 Purpose	3
1.2 Technical Characteristics (features)	3
1.3 In Box	4
1.4 Design and Operation	4
1.5 Marking and Sealing.....	6
1.6 Package.....	6
2. Using the Product.....	6
2.1 Operational Restrictions.....	6
2.2 Getting Started	6
2.3 Using the Product.....	7
2.4 Operation in Extreme Conditions.....	8
3 Technical Maintenance of the Product.....	8
4. Product Minor Repair	8
5. Storage	9
6. Transportation	9
7. Disposal	9

This Operation Manual (OM) is intended for proper and safe operation of IRBIS Eyepieceless Thermal Sight (hereinafter referred to as 'product' or 'device') and the assessment of its technical condition when considering the necessity to send it for repair. Product maintenance does not require any special training of staff.

1. PRODUCT OPERATION

1.1 Purpose

1.1.1 Irbis eyepieceless thermal sight is designed to detect and identify targets at close range, to be used as a sight for assault weapons of normal caliber, to work in difficult weather conditions at high level of natural and other interference: fog, snow, rain, dust, blinding light.

1.2 Technical Characteristics (Features)

1.2.1 Effective firing distance at least 100 ± 5 m;

1.2.2 Type of radiation receiver - uncooled aSi microbolometer;

1.2.3 Focal length of the base lens: 25 mm.

1.2.4 Number of sensitive elements of the detector (matrix) 384 x 288 pixels;

1.2.5 Operating spectral range: from 8 to 14 microns;

1.2.6 Minimum distinguishable temperature difference: $0.05 \text{ }^\circ\text{C}$;

1.2.7. Field of view of the base lens horizontally ($14.9 \pm 1 \text{ }^\circ$) and vertically ($11.2 \pm 1 \text{ }^\circ$).

1.2.8 Built-in color display with a diagonal of 1.7 ", a resolution of 320 x 240 pixels.

1.2.9 Power is supplied from two Li-ion (or lithium) batteries of CR123A.

1.2.10. Time of continuous operation from one set of batteries in normal climatic conditions is at least 3 hours.

1.2.11 The product has the following functions and adjustments:

- battery status indication;
- switching between display modes of thermal image: hot-white (positive), hot-black (negative);
- changing color palette of thermal image (at least 6 options);
- setting display brightness;
- digital zoom 1x, 2x, 4x;
- selecting the type of reticle (at least 3);
- reticle position control (up-down, right-left).

1.2.12 Time to enter operating mode after power-up no more than 5 s.

1.2.13. Installation time (or closing-down, with placing in a standard packing) is no more than 3 minutes.

1.2.14 Overall dimensions of the device $(110 \pm 5) \times (67 \pm 5) \times (69 \pm 5)$ mm.

1.2.15 Weight of the device with batteries (0.4 ± 0.1) kg.

1.2.16 Protection class against dust and water IP65 according to GOST 14254-96.

1.2.17 Climatic operating conditions of the device:

- operating temperature range from minus 0 to plus $40 \text{ }^\circ\text{C}$;
- relative air humidity of not more than 95% at a temperature of plus $25 \text{ }^\circ\text{C} \pm 1 \text{ }^\circ\text{C}$.

1.3. In Box

1.3.1 Product Delivery Set is specified in Table 1.

Table 1

Name	Pcs
IRBIS device	1
Power supply set	1 set
Charger *	1
Bar mount of the WEAVER type	1
Field cover	1
Pencil for cleaning optical lenses and coatings	1
Cloth for cleaning optics	1
Operation Manual	1
Data Sheet	1
Standard transport package	1

Note - The charger, power elements, and case can be replaced by the ones that are similar in technical specifications.

1.4 Design and Operation.

1.4.1 The main components of the device and the control layout are shown in Figure 2 and 3

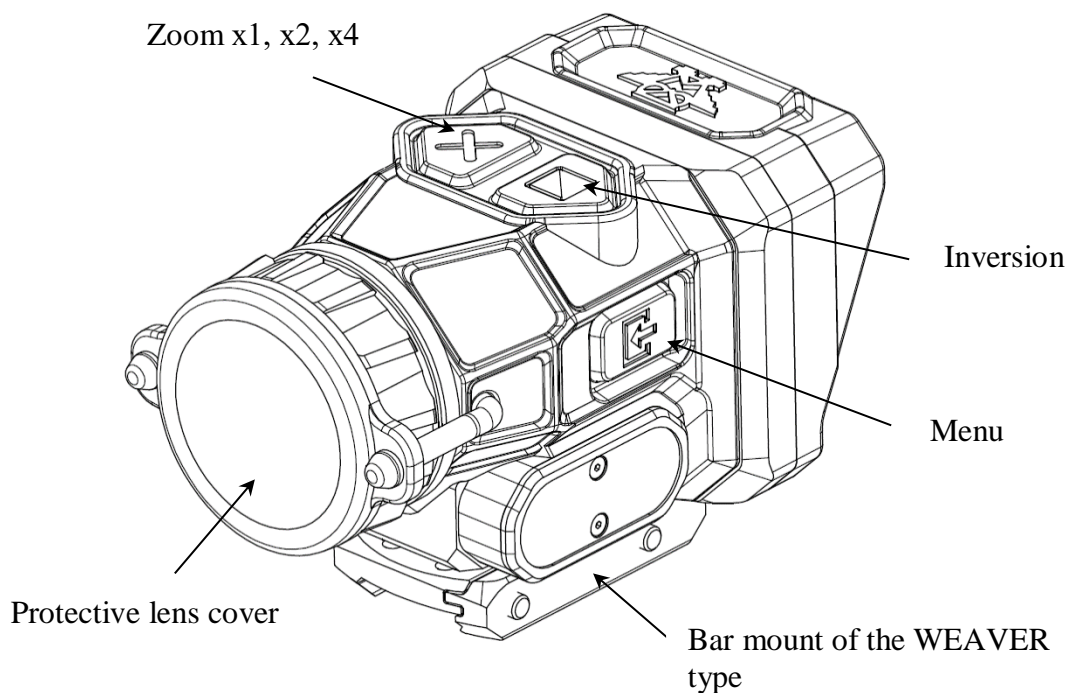

Figure 2

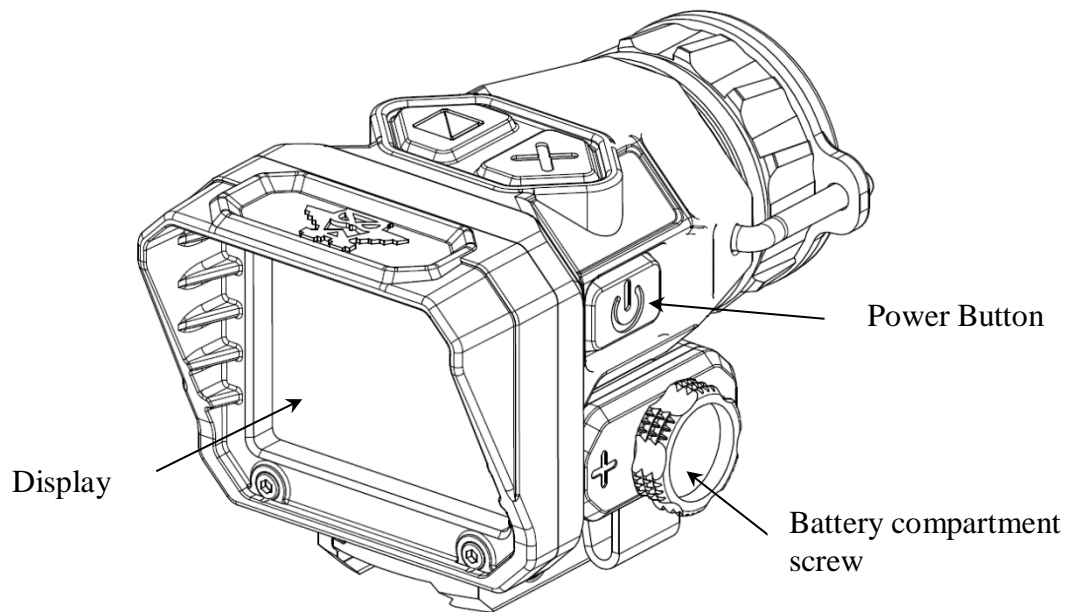

Figure 3

1.4.2 There are 4 functional buttons Power, Menu, Zoom, Inversion (see Figure 4) to control parameters and operation modes of the device through Menu on the display. Use Power button to turn the device on/off.



Figure 4

1.4.3 In front of the device there is a lens and a battery compartment, with a cover fixed by a screw.

1.4.4 The case of the device in black (opaque protective) color is made of alloyed metal with rubberizing.

1.4.5 The observed objects are visualized through the built-in display.

1.4.6. On the lower part of the device there is a bar mount of WEAVER type.

1.5. Marking and Sealing.

1.5.1. Marking of the product, which includes short name of the manufacturer, individual serial number, part number and year of manufacture is marked on the code plate on the case of the device and on the package (case). The case with the product is packed in a cardboard box.

1.5.2. The product is sealed (if needed) on a standard package (case). The product itself is not sealed.

1.6. Package

1.6.1. The product is packed in a standard package (plastic case).

1.6.2. The product in a standard package is packed in a matched transport packaging (cardboard box).

2. USING THE PRODUCT

2.1. Operational restrictions

2.1.1. Before starting, carefully read this Operation Manual

2.1.2 When finished, power off the device to prevent battery discharge during transportation and storage.

2.1.3. **Do not** open battery compartment of the product, replace batteries, remove protective lid of the battery compartment and lens in the conditions of high humidity (over 90%), condensate, or the possibility of water penetration into the interior content of the product and its parts.

2.1.4 **Do not** immerse the product into water, do not power the product in case of water ingress, do not operate the product at temperatures beyond the limits specified in p. 1.2.17.

2.1.5. Replacement of battery should be carried out only when the device is powered off.

2.1.6 **Do not** power the device with other sources, including structurally similar, except for regular rechargeable battery and a standard power supply unit.

2.1.7 Do not close the connections of power supply, that will lead to their failure

2.1.8 Do not store power supply units at temperatures above plus 60 °C, for example, in a car left in the sun.

2.1.9 In the case of operation at low temperatures, in order to maintain the given capacity of power sources, it is recommended to store them in warm places, for example, in a pocket and insert them into the device immediately before use.

2.2. Getting Started

2.2.1. Before using the device, make sure there is no violation of operational restrictions specified in p. 2.1.

2.2.2 Unpack the device and power supply sources

2.2.3. Make sure there is no mechanical or chemical damage on the power units. Check for any mechanical damage on the product.

2.2.4. Install functional rechargeable batteries carefully observing proper position.

2.2.5. Close battery compartment lid tight to prevent penetration of foreign objects and water into the case while operating the device.

2.2.4. Turn on the device and make sure the battery is fully charged

2.2.5. Charge the battery using regular charger

2.2.6. If rechargeable batteries are not charged (upon delivery of the product with batteries), charge them with the charger. To do this, unscrew the screw securing battery cover and remove the batteries from the device. Install the batteries into the charger, observing polarity indicated on the charging device and connect the charger to the AC 220 V.

2.2.7 To charge Li-ion batteries, remember the following:

- it is not necessary to discharge the battery before charging, since residual charge of the battery does not affect its nominal capacity;
- recommended ambient temperature when charging should be in the range from plus 10 to plus 30 °C;
- do not power the charger outside in rain or increased humidity more than 95 %
- the battery should be charged on a flat surface without vibration;
- while charging, the charger may get warm, which is normal.

2.3 Using the Product

2.3.1 Power-On

- open protective lens cover; to power the device on/off hold the Power button for 3 sec

2.3.2 Configuring

- to adjust the lens to the desired viewing distance, select the object at an appropriate distance and by rotating lens adjustment ring, get clearest image of the object.

- to enter settings menu, press and hold the Menu button for 3 s and select the necessary section with a short press of the Menu button: palette, zoom, crosshairs, moving the crosshairs along the X and Y axes. To change the necessary menu section, use buttons Zoom and Inversion.

2.3.3 Positive/Negative option

- to activate this function, press Inversion button once (at least 1s). To go back to the initial display mode, press the button again. After the device has been enabled, the Positive mode is initially used, i.e. hot objects are displayed lighter than cold objects. When Negative mode is activated, hot objects appear darker than cold objects.

2.3.4 Image Zoom

- use Menu button or Zoom button; to do this, press the Zoom button briefly, x2 mode will be activated, then x4 of electronic image zoom, the next pressing of the button will return the original display mode x1.

2.3.5 Palette Types

- the type of palette is changed in the menu, types of palettes are as follows: PAL1 (gradation of grey), PAL2 (grey-red), PAL3 (iron), PAL4 (medical), PAL5 (rain), PAL6 (rainbow), PAL7 (amber).

2.3.6 Configuring crosshair display

- use Menu of the device, types of possible crosshairs: mildot, crosshair, point, crosshair off.

2.3.7 Moving crosshairs along X and Y axes

- to move crosshair along the axes, select the desired X or Y axis in the menu and use Zoom and Inversion buttons to set crosshair to the desired object.

2.3.8 The built-in battery status indicator is displayed in the upper right corner when viewing in the eyepiece after the device has been enabled.

2.3.9 Follow the reverse procedure to switch the device off.

2.4. Operation in extreme conditions.

2.4.1. In case of fire on the device, power off the device and take measures to put out fire.

2.4.2. In case of emergency operating conditions (high temperature, humidity, vibration, etc.), take measures to reduce the impact of emergency factors on the product.

3. TECHNICAL MAINTENANCE OF THE PRODUCT

3.1. Product maintenance does not require special training of staff.

3.2. Any oxidation and salt presence on the surfaces of the batteries must be avoided. When any appear, the batteries must be replaced.

3.3. 3.3. Optical surfaces of the device (eyepiece, lens) when dirty should be cleaned only with a clean cloth made of genuine or microfiber suede, designed for cleaning optical parts (eg glasses). Before that blow away the grains of sand and dust. To remove heavy grease, use a cotton swab moistened in ethanol, having preliminary removed solids from the optics with a soft brush.

3.4. Product functional testing and its technical inspection is controlled by checking paragraphs 1.2.11, 1.2.12.

3.5. Replacing the battery is required in case of their failure or due to a significant loss of capacity. The criterion for battery replacement is decrease in the time of continuous operation from a fully charged battery to less than 70% of the nominal.

3.6. Preservation (degreasing, reconservation) of the product is carried out by packing it in its standard package (plastic case).

4. PRODUCT MINOR REPAIR

4.1. Minor repair of the product is carried in accordance with Table 2.

Table 2

Failure and damage consequences	Possible Reasons	Troubleshooting
When powered, there is no image on display in the eyepiece.	Battery capacity is exhausted Contacts in battery compartment have been oxidized	Replace the batteries Clean contacts in battery compartment
When in operation, there are constant interfering glares, stains	The lens of the device is contaminated	Clean the lens with a clean cloth made of genuine or microfiber suede
The symbols of the batteries on the charger (upon delivery of the product with batteries and chargers) begin to flash, and the batteries indication is dim	Power supply units are installed incorrectly into the charger. No contact with the charger	Install power supply units into the charger in the way to get contact. If necessary, carefully bend upward fixing plastic latch located between the contacts of the charger.

Note - If measures to eliminate failures listed in the table do not allow restoring the product to its operability, it should be directed over to the manufacturer for repair

5. STORAGE

5.1. Storage conditions.

5.1.1. The device must be stored packed (in case) on the shelves in the capital heated rooms at temperature from 5 ° C to + 40 ° C and a relative humidity of 80% at temperature of +25 ° C at no vapors of acids, alkalis, current-conducting dust and other chemically active substances, gases that cause corrosion and destroy insulation. It can be stored in a standard package when stacked (horizontally) on the shelves with up to 4 products. Stacking in a vertical position is not allowed.

5.2. Storage life

5.2.1. Storage life of the product in a standard package is 1 year in heated ventilated premises at ambient temperature from + 5°C to + 40°C and a relative humidity of up to 80% at temperature of 25 ° C.

5.3. Terms of placing the product in storage and withdrawing it from storage.

5.3.1. When placing the product for storage, pack it in standard package and place on the corresponding cells. When withdrawing it from storage, the components of the product should be removed from the package and kept under standard climatic conditions (ambient temperature $20 \pm 5^{\circ}\text{C}$, relative humidity from 45 to 80%, atmospheric pressure from $8.6 \cdot 10^4$ to $10.7 \cdot 10^4$ Pa), for at least 12 hours.

6. TRANSPORTATION

6.1. Requirements for transportation and transportation conditions.

6.1.1. Transportation of the device is carried out in a transport container by all kinds of goods and passenger transport at a height of up to 12,000 meters at ambient temperatures from - 30 ° C to + 50 ° C and protected against direct exposure of precipitation and reactive components. When carried in railway wagons, the shipment should be small low-tonnage. After transportation and before using, keep the product in standard climatic conditions for at least 12 hours.

6.2. The procedure to prepare the product for transportation and methods of attachment during transportation.

6.2.1. Before transporting the product in a standard package, it can be packed into an extra matched shipping container (carton or plywood box). Products in transport containers should be secured in such a way as to ensure the stability of their position, excluding mutual displacement and strokes. During loading, unloading and transporting, the requirements of handling marks on the shipping container must be strictly observed.

7. DISPOSAL

7.1 Product disposal must comply with environmental standards.

7.2 The batteries used in the product, after the end of life (or failure), must be disposed at a specialized enterprise in the prescribed manner.

7.3. Arrangements for preparation and shipment of the product for recycling include disassembly, disassembly into components and parts with homogeneous materials.

7.4. Materials are sent for recycling in the order established by the consumer.